

15 DECEMBER 83

(Supersedes LO 5-3895-372-12, 5 OCTOBER 1979)

**CONCRETE-MOBILE MIXER BODY M919 MODEL 8CM-24F  
(NSN 3895-01-028-4391)**

Reference: TM 5-3895-372-10, and -20, LO 9-2320-273-12 and FEDERAL SUPPLY CATALOG C9100-IL.

Hard time intervals and the related manhour times are based on normal operation. The man-hour time specified is the time you need to do all the services prescribed for a particular interval.

Change the hard time interval if your lubricants are contaminated or if you are operating the equipment under adverse operating conditions, including longerthan-usual operating hours. The hard time interval may be extended during periods of low activity. If extended, adequate preservation precautions must be taken.

**WARNING**

Dry cleaning fluid is flammable. Do not use near a flame or excessive heat. Use only with adequate ventilation. Avoid prolonged breathing of vapors and minimize skin contact.

Clean parts or fittings with dry cleaning solvent (SD), Type II or equivalent. Dry before lubricating. Dotted arrow shafts indicate lubrication on both sides of equipment. A dotted circle indicates a drain below. Relubricate all items found contaminated after fording or washing.

The lowest level of maintenance authorized to lubricate a point is indicated by one of the following symbols as appropriate: Operator/Crew (C); and Organizational Maintenance (O).

**Reporting errors and recommending improvements.** You can help improve this manual. If you find any mistakes, or if you know of a way to improve the procedures, please let us know. Mail your letter or DA Form 2028 (Recommended Changes to Publications and Blank Forms) direct to: Commander, US Army Tank-Automotive Command, ATTN: DRSTA-MB, Warren, MI 48090. A reply will be furnished to you.

\*The time specified is the time required to perform all services at the particular interval.

*TOTAL MAN-HOURS		*TOTAL MAN-HOURS	
INTERVAL	MAN-HOURS	INTERVAL	MAN-HOURS
D	0.6	S	1.2
W	2.5	B	0.5
M	0.5		

TA 219684

**LUBRICANT•INTERVAL**

**INTERVAL•LUBRICANT**

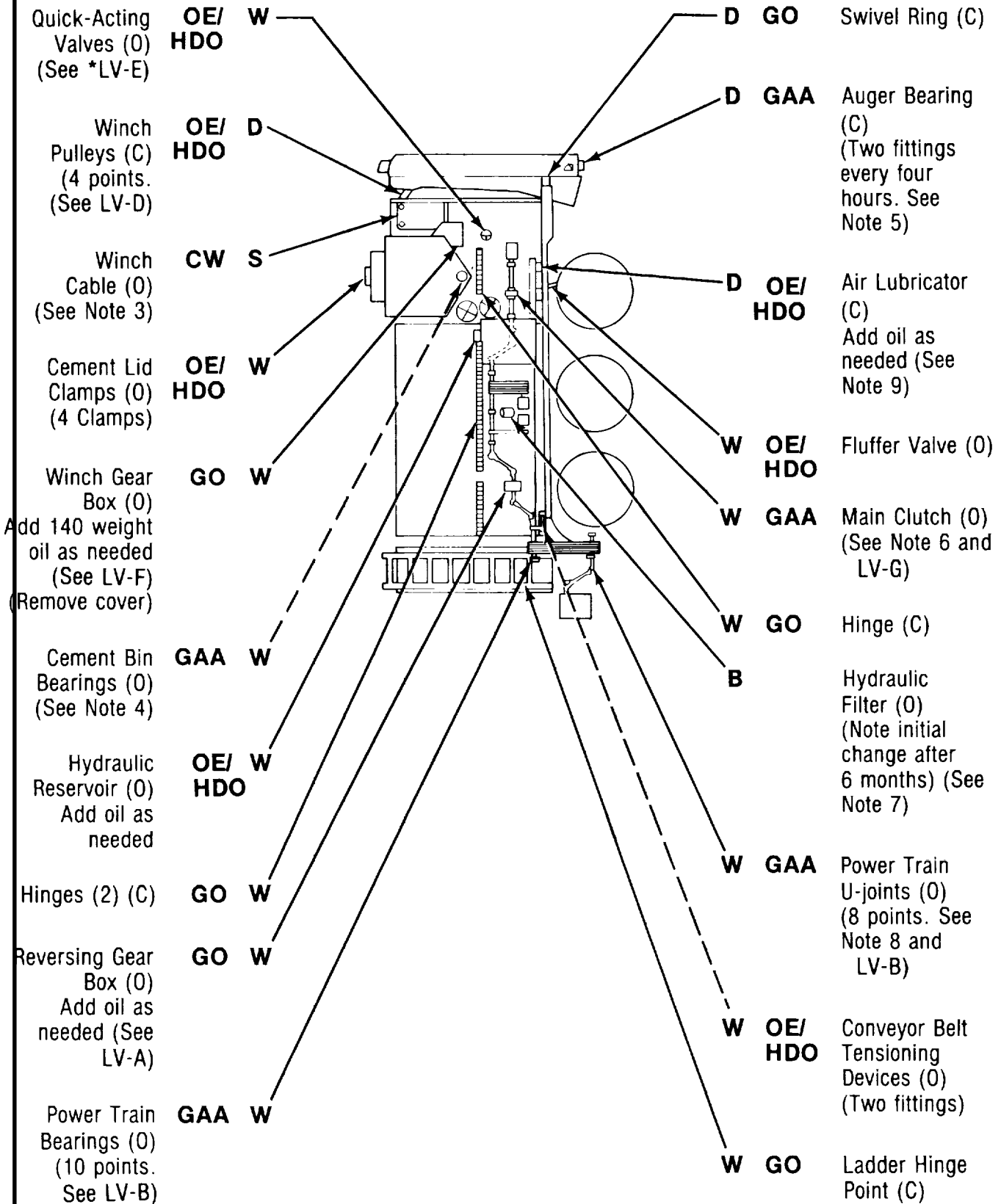

Quick-Acting Valves (O)  
(See \*LV-E)

Winch Pulleys (C)  
(4 points.  
(See LV-D)

Winch Cable (O)  
(See Note 3)

Cement Lid Clamps (O)  
(4 Clamps)

Winch Gear Box (O)  
Add 140 weight oil as needed  
(See LV-F)  
(Remove cover)

Cement Bin Bearings (O)  
(See Note 4)

Hydraulic Reservoir (O)  
Add oil as needed

Hinges (2) (C)

Reversing Gear Box (O)  
Add oil as needed (See LV-A)

Power Train Bearings (O)  
(10 points.  
See LV-B)

D GO Swivel Ring (C)

D GAA Auger Bearing (C)  
(Two fittings every four hours. See Note 5)

D OE/HDO Air Lubricator (C)  
Add oil as needed (See Note 9)

W OE/HDO Fluffer Valve (O)

W GAA Main Clutch (O)  
(See Note 6 and LV-G)

W GO Hinge (C)

B Hydraulic Filter (O)  
(Note initial change after 6 months) (See Note 7)

W GAA Power Train U-joints (O)  
(8 points. See Note 8 and LV-B)

W OE/HDO Conveyor Belt Tensioning Devices (O)  
(Two fittings)

W GO Ladder Hinge Point (C)

**LEFT VIEW**

219685

\*LV - Locator views, to assist the user are found immediately after the last illustration.

**LUBRICANT • INTERVAL**

**INTERVAL • LUBRICANT**

**COVERS REMOVED**

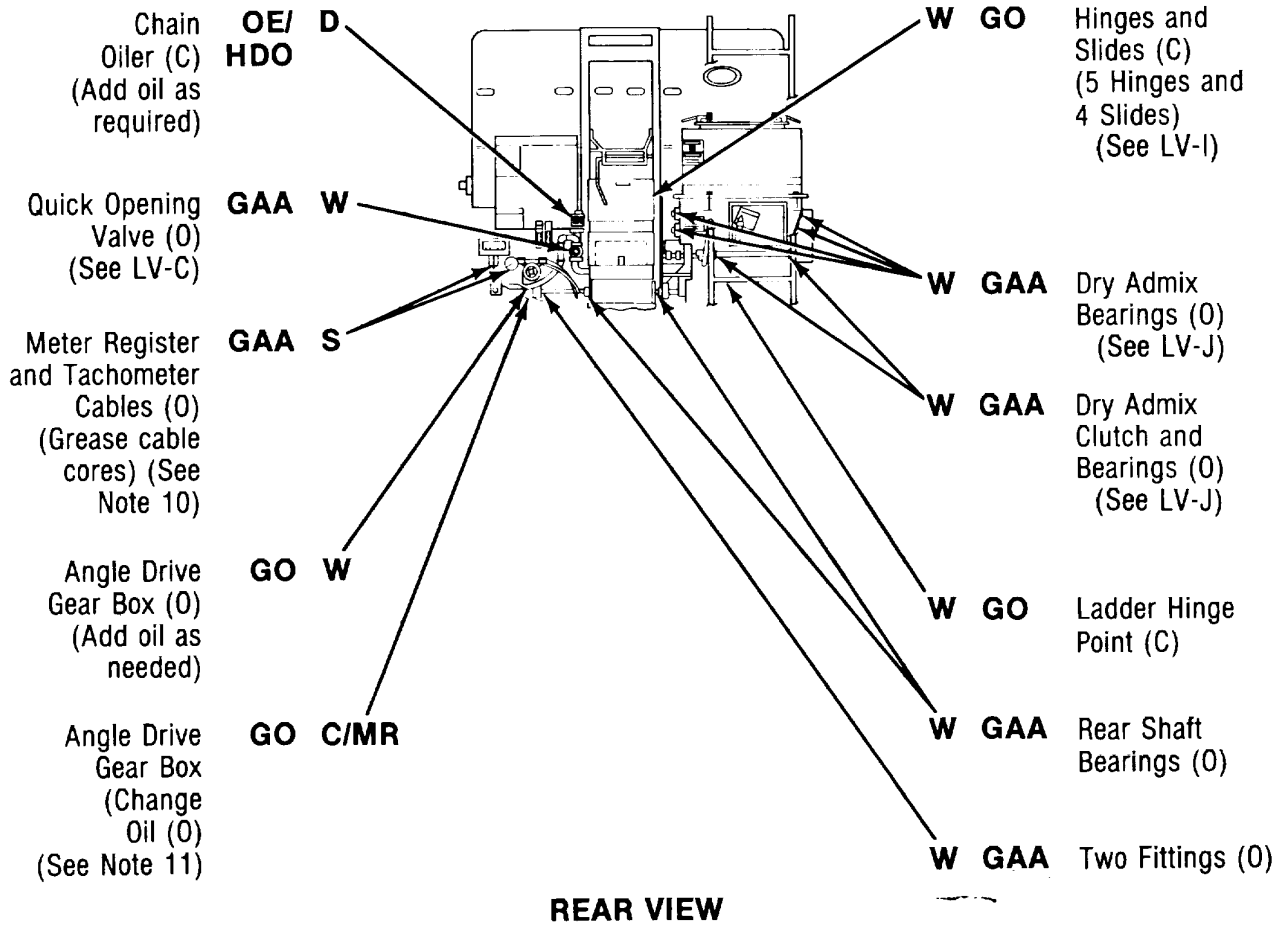
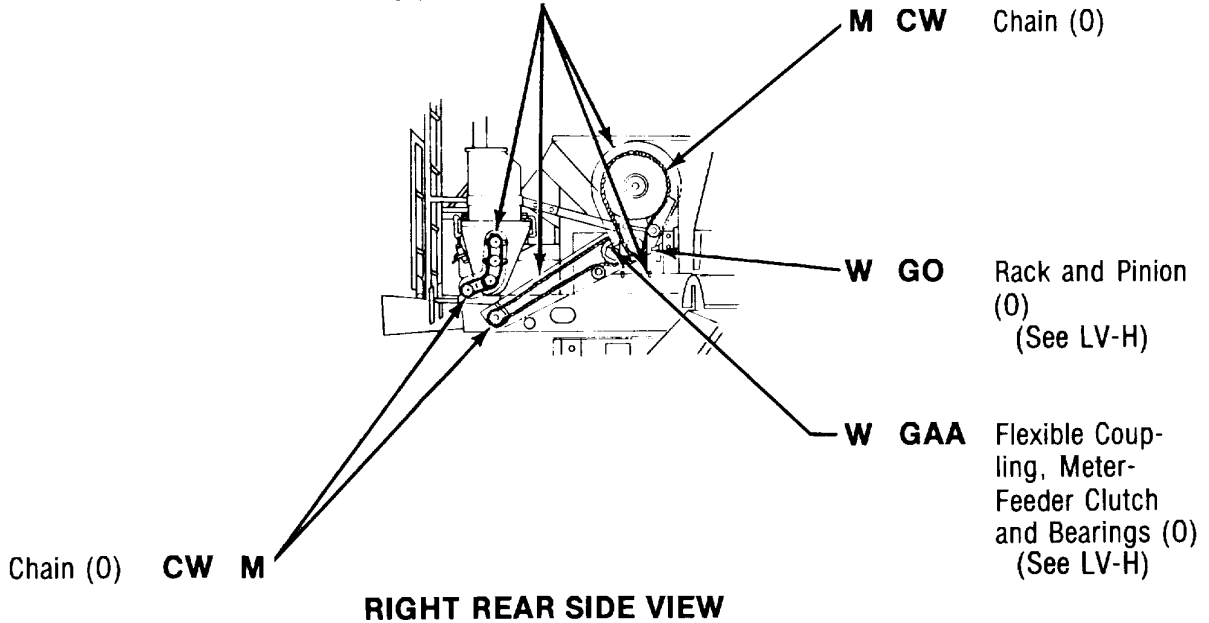

TA 219686

LV-A Reversing Gear Box

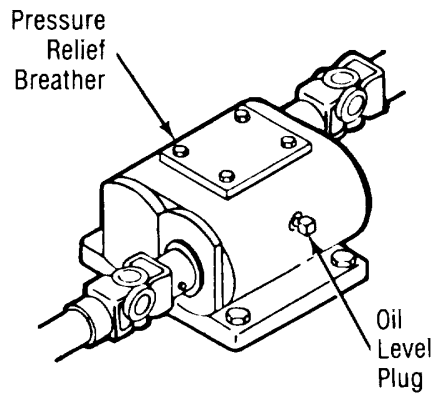

LV-B Power Train

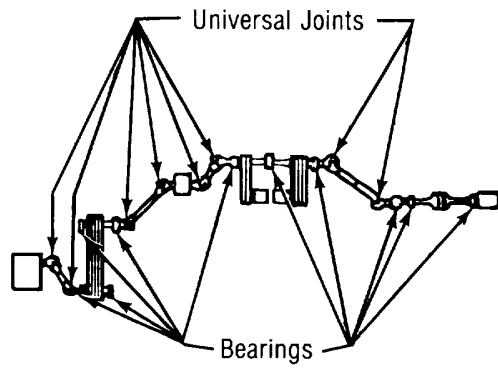

LV-B Quick-Opening Valve

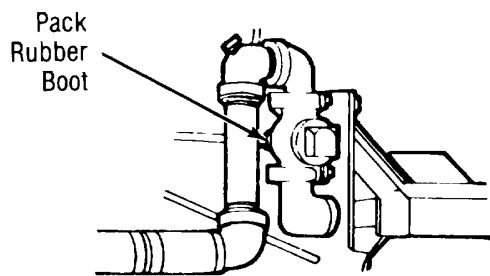

LV-D Pulleys

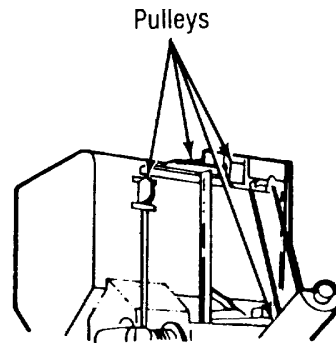

LV-E Quick-Acting Valves

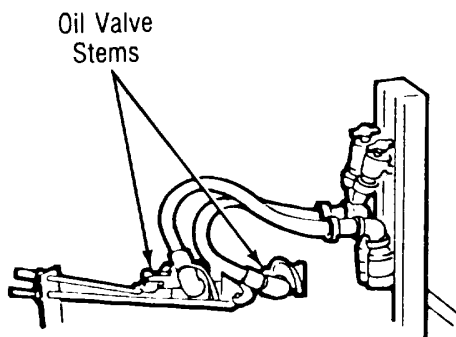

LV-F Winch Gear Box

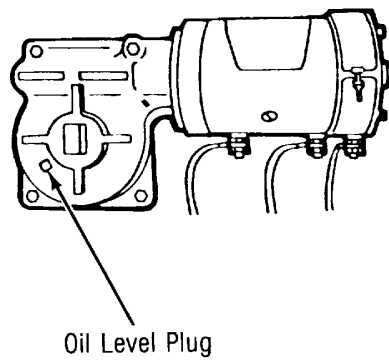

TA 219687

LV-G Main Clutch

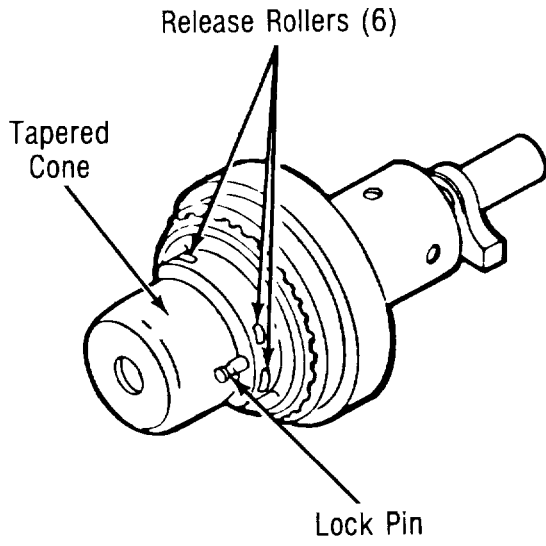

LV-H Rack and Pinion Meter-Feeder

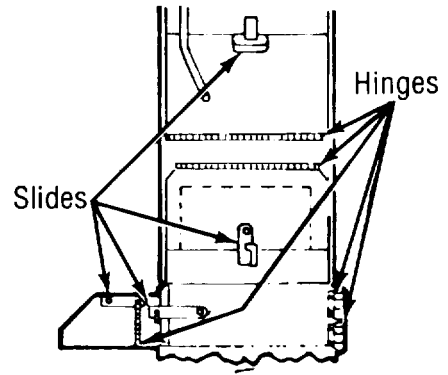

LV-J Dry Admix

Dry Admix Bearings

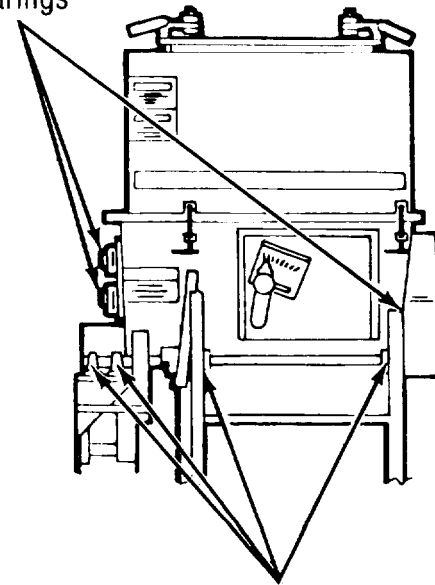

LV-I Hinges and Slides

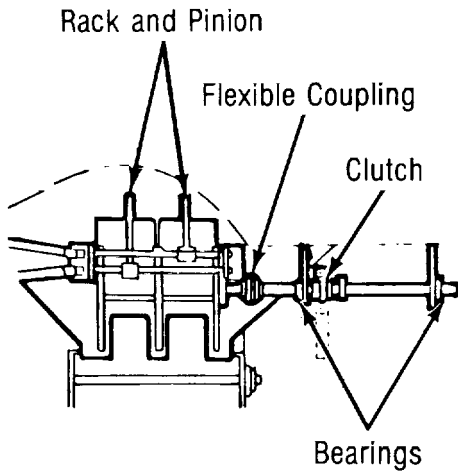

\* KEY -

LUBRICANTS	CAPACITY	EXPECTED TEMPERATURES			INTERVALS
		Above +15°F (Above -9°C)	+40° to -15°F (+4° to -26°C)	+40° to -65°F (+4° to -54°C)	
<b>OE/HDO</b> - Lubricating Oil, Internal Combustion Engine, Tactical Service  <b>OEA</b> - Lubricating Oil, Internal Combustion, Arctic  - Oil Can Points (See Note 2)  - Winch Cables  - Main Clutch  - Air Lubricator  - Hydraulic Reservoir		OE/HDO 30	OE/HDO 10	OEA (See Note 1)	C/MR - Condition Monitor            Intervals given are in hours of normal operation.
<b>GO</b> - Lubricating Oil, Gear, Multipurpose  - Oil Can Points (See Note 2)  - Angle Drive Gear Box  - Reversing Gear Box  - Winch Gear Box		GO 80W/90	GO 80W/90	GO 80W/90	
		GO 85W/140	GO 85W/140	GO 85W/140	
<b>GAA</b> - Grease, Automotive and Artillery		ALL TEMPERATURES			
<b>CW</b> - Lubricating Oil: Chain, Wire Rope, Exposed Gear		CW-IIB (GRADE B)	CW-IIB (GRADE B)	CW-IIA (GRADE A)	

For Arctic operation refer to FM 9-207

\*See Note 12 for lubricant specification number.

NOTES

1. FOR OPERATION OF EQUIPMENT IN PROTRACTED COLD TEMPERATURES BELOW -150F (-260C). Remove lubricants prescribed in Key for temperatures above -150F (-260C). Relubricate with lubricants specified in Key for temperatures below -150F (-260C). If OEA lubricant is required to meet the temperature ranges prescribed in the Key, OEA lubricant is to be used in place of OE/HDO-10 lubricant for all temperature ranges where OE/HDO-10 is specified in the Key.

2. OIL CAN POINTS. Each day lubricate winch pulleys with OE/HDO and swivel rings with GO. Each week lubricate quick acting valves, cement lid clamps, fluffer valve, conveyor belt tensioning devices with OE/HDO and hinges, ladder hinge point, rack and pinion, and slides with GO.

3. WINCH CABLES. Semiannually, unwind entire cable, clean and oil. Using a brush soak with OE/HDO. Wipe off excess and coat with CW before rewinding cable on drum.

4. CEMENT BIN BEARINGS. To avoid getting grease in cement bin, do not overlubricate.

5. AUGER BEARING. Lubricate while auger is turning. Flush with grease every 4 hours during operation, and at every cleanup. This bearing cannot be greased too often or too much.

6. MAIN CLUTCH. Apply several drops of OE/HDO oil on the lock pin and release rollers through the 6 holes in the clutch cover. Oil the tapered cone.

7. HYDRAULIC FILTER. After initial 6 month change, each 2 years remove element, clean filter shell, and install new element. After replacement, operate for 5 minutes, check for leaks, check level and bring to full mark.

8. POWER TRAIN UNIVERSAL JOINTS. Each week turn prop shaft by hand to gain access to lub fittings. Do not JOINITS. Each week turn prop shaft by hand to gain access to lub fittings. Do not

overlubricate. Excess grease will burst seals.

9. AIR LUBRICATOR. Each day check oil in sight glass. If oil is not visible remove bowl and fill with OE/HDO.

10. METER REGISTER AND TACHOMETER CABLES. Each 6 months remove cables from meter register and tachometer ends, lubricate with GAA and reinstall.

11. ANGLE DRIVE GEAR BOX. Check level each week. Change gear lubricant only when required by maintenance repair action, contamination by water or other foreign material. After refill, operate for 5 minutes, check for leaks and bring oil to full mark.

12. LUBRICANTS. The following is a list of lubricants with military symbols and applicable specification numbers.

OE/HDO	MIL-L-2104
GO	MIL-L-2105
GAA	MIL-G-10924
OEA	M IL-L-46167
CW	VV-L-751 D
(SD), Type II	P-D-680

Copy of this Lubrication Order will remain with the equipment at all times, instructions contained herein are mandatory.

By order of the Secretary of the Army:

JOHN A. WICKHAM, JR.  
General, United States Army  
Chief of Staff

OFFICIAL:

ROBERT M. JOYCE  
Major General, United States Army  
The Adjutant General

DISTRIBUTION:

To be distributed in accordance with DA Form 12-25B, Operator and Organizational maintenance requirements for Concrete Mixers.

RECOMMENDED CHANGES TO EQUIPMENT TECHNICAL PUBLICATIONS



THEN... JOT DOWN THE DOPE ABOUT IT ON THIS FORM, CAREFULLY TEAR IT OUT, FOLD IT AND DROP IT IN THE MAIL!

SOMETHING WRONG WITH THIS PUBLICATION?

FROM: (PRINT YOUR UNIT'S COMPLETE ADDRESS)

DATE SENT

PUBLICATION NUMBER

PUBLICATION DATE

PUBLICATION TITLE

BE EXACT... PIN-POINT WHERE IT IS

PAGE NO.

PARA-GRAPH

FIGURE NO.

TABLE NO.

IN THIS SPACE TELL WHAT IS WRONG AND WHAT SHOULD BE DONE ABOUT IT:

TEAR ALONG PERFORATED LINE

PRINTED NAME, GRADE OR TITLE, AND TELEPHONE NUMBER

SIGN HERE:



